



**VENMAR CES**<sup>INC.</sup>  
COST-EFFECTIVE COMMERCIAL VENTILATION™

# Installation, Operation and Maintenance Instructions

---

HRV450w • HRV1000w



HRV450w



HRV1000w

Heat Recovery Ventilators with Electric or Hydronic Heating

# Table of Contents

<b>Safety Considerations</b> .....	3
<b>Specifications</b> .....	3
<b>Installation</b>	
Rough In.....	3
Power .....	4
Controls.....	4
Airflow Balancing.....	4
<b>System Operation</b>	
Sequence of Operation .....	5
Ventilation.....	5
Heating.....	5
High Temperature Limit Control .....	5
First Stage Cooling.....	5
Second Stage Cooling - Air Conditioning.....	6
Recirculation Control.....	6
Frost Control .....	6
Freeze Control Temperature Disc.....	6
<b>System Service</b>	
Monthly Maintenance.....	6
Annual Maintenance .....	7
<b>Appendix A-1: HRV450w Overall Dimensions</b> .....	8
<b>Appendix A-2: HRV450w Coil Dimension Drawings</b> .....	9
<b>Appendix B-1: HRV1000w Overall Dimensions</b> .....	10
<b>Appendix B-2: HRV1000w Coil Dimension Drawings</b> .....	11
<b>Appendix C-1: HRV450w Ventilation Graph</b> .....	12
<b>Appendix C-2: HRV1000w Reduced Low Speed Airflow Information</b> .....	12
<b>Appendix C-3: HRV1000w High Speed and Regular Low Speed Airflow Information</b> .....	13
<b>Appendix D: Electrical Data</b> .....	14
<b>Appendix E: Low Voltage and High Voltage Wiring</b> .....	15
<b>Appendix F: Thermostat and Wiring Connections</b> .....	16
<b>Appendix G: Internal Thermostat</b> .....	17

Manufacturer reserves the right to discontinue or change specifications or designs without notice or obligation.

## Safety Considerations

Hazards may exist within this equipment because it contains electrical and powerful moving components. Only qualified service personnel should install or service this equipment. Untrained personnel can perform basic maintenance such as maintaining filters. Observe precautions marked in literature and on labels attached to unit. Follow all safety codes.

### WARNING

Disconnect the main power switch to the unit before performing service or maintenance. Electric shock can cause personal injury.

## Specifications

The Wallmount Ventilator Series is one of the successful solutions to ventilation and indoor air quality problems from Venmar CES. This series consists of commercial heat and energy recovery ventilators with heating and/or cooling. Designed as appliances, they are ideally suited as complete classroom ventilators. With an upright configuration and small footprint, they require a minimum amount of space for installation. An optional top supply plenum allows for flexibility to suit various installations. The cabinet is well insulated and tightly sealed to provide quiet operation.

### Case:

- 0.04" [1mm] pre-finished steel
- Heavy gauge pre-finished steel
- Smooth texture
- Bone white finish

### Unit Dimensions:

- HRV450w - See Appendix A-1
- HRV1000w - See Appendix B-1

### Coil Dimension Drawings:

- HRV450w - See Appendix A-2
- HRV1000w - See Appendix B-2

### Supply and Exhaust Airflow:

- See Appendix C-1, C-2 and C-3.

### Heat Recovery Module:

- Polypropylene plate - Standard
- Aluminum plate - Optional
- Co-extruded tracks fit to allow for easy removal and maintain low cross leakage
- 68% to 70% with heat recovery modules at rated flow of 450 cfm

### Filtration (Supply and Exhaust):

- *HRV450w* - 1" [25mm] reticulated foam washable filter 14" x 18" [356 x 457mm] standard
- *HRV1000w* - 2" [51mm] MEF disposable filter 16" x 20" [406 x 508mm] standard

### Electric Heating Option:

- Open coil electric resistance elements
- Two stage operation:
  - **Stage One** - 2.5kW to 5.0kW 208/230V, 1 phase, 60Hz
  - **Stage Two** - 2.5kW to 5.0kW (HRV450w) 2.5kW to 10.0kW (HRV1000w) 208/230V, 1 phase, 60Hz

### Hydronic Heating Option:

- Aluminum hot water coil
- Single stage operation:
  - 25,000 Btu coil (7.3 kW)** - HRV450w
  - 50,000 Btu coil (14.6 kW)** - HRV450w, HRV1000w
  - 70,000 Btu coil (20.5 kW)** - HRV1000w

## Installation

### Rough In

The wallmount ventilators must be installed on a level base. Refer to Appendix A-1 and B-1 for dimensions. Zero clearance is required between the bottom of the unit and any combustible material.

### Unit Installed Without a Top Plenum

The supply air ducting must be connected to the supply collar and constructed so there are no openings within 30" [762mm] of the electric heating elements. Openings within 30" [762mm] of the elements must be fitted with a permanent, non-removable protective screening. Zero clearance is required between the supply duct and any combustible material.

### Drainage - Heat Exchanger/Cooling Coil

Units equipped with air conditioning have a condensate line connected at the top of the unit which drains into the main condensate line. The heat exchanger and cooling coil drain must be fitted through the bottom of the case. Drain connections within the case are accessible by removing the bottom door. A length of PVC hose is supplied within the case to make the drain connection.

A water trap must be provided in the drain line to prevent back flow of sewer gases. This trap may be achieved by looping the drain line. The drain must be installed in an area in which it will not freeze. If the wallmount ventilator has a collector base, the drain hose will be located in the base.

## Power

### WARNING

Ensure the power disconnect switch is off before connecting power to the unit or working with high voltage lines.

A sealed strain relief clamp (supplied by the installer) must be fitted into the case to accommodate a power line connection (see Appendix A-1 and B-1 for knockout location). If a sealed clamp cannot be used, the hole must be sealed with silicone or an equivalent water/air tight sealant. Power must be connected to the unit through a fused disconnect switch (to be supplied by the installer). If the unit has a top supply plenum, a hole for the power must be field drilled in the plenum to accommodate the main power in.

Terminals for line connection are located in the control box within the wallmount ventilator and are labeled as shown below. Connections are illustrated in Appendix E.

**Single Phase** - Line connection to 208 VAC or 230 VAC, 1 phase, 60Hz for electric heat.

L1	- Hot	Black
L2	- Hot	Red
N	- Neutral	White
GND	- Ground	Bare
L1	- N	120 VAC 60Hz
L1	- L2	230 VAC 60Hz or 208 VAC

Line connection to 120 VAC 60Hz is required for units with hydronic heating.

L1	- Hot	Black
N	- Neutral	White
GND	- Ground	Bare
L1	- N	120 VAC 60 Hz

A wiring diagram is supplied in Appendix E.

## Controls

### External Switches

The wallmount ventilator controls (optional with Building Management system), are located on the left side panel. These controls consist of two rocker switches. The switches are labeled 'Ventilation Rate' and 'First Stage Heating'. The 'Ventilation Rate' switch sets the fan speeds to 'Low', 'Off', or 'High'. This switch is activated through terminal G and is also a system switch for an internal thermostat. The 'First Stage Heating' switch engages or disengages the function of the internal thermostat. On versions with hydronic heating, there will be no 'First Stage Heating' switch.

### External Thermostat

Heating, cooling and ventilation can be controlled by a remote thermostat. The wiring configuration for the thermostat subbase is shown in Appendix F. Ventilation may otherwise be remote controlled by switching R to FL or FH. A separate information package on the subbase is supplied with the wallmount ventilator.

The thermostat may be remote mounted on a nearby wall. If it is remote mounted, control wire leads must be fitted into the case through a sealed strain relief clamp where required. If a proper seal cannot be achieved with the clamp, use silicone or an equivalent water/air tight sealant.

### Control Box Low Voltage Connections

Building Management System connections will vary by application. All control connections to the external thermostat are 24 VAC 60 Hz.

Wire Color	Connection and Description
Black	R - 24 VAC Hot
White	C - 24 VAC Common
Orange	W1 - Stage 1: Heating and signal for baseboard contactor (optional)
Red	W2 - Stage 2: Heating and recirc
Yellow	Y1 - Stage 1: Free Cooling Y2 - Stage 2: Dx Cooling (optional)
Violet	S1 - Occupied mode S2 - N/A C1 - N/A FL - Fans low speed
Brown	FH - Fans high speed
Green	G - Fans auto (low)

Detailed control wiring is illustrated in Appendix E.

### Internal Thermostat

An internal thermostat will engage Stage One when the supply air temperature falls below its setpoint. The function of this thermostat is disabled when the external heating switch is set to 'Off'. The operation of this thermostat is given in Appendix G. This thermostat is not available with the Hydronic heating option or Building Management System option.

### Building Management Systems

Control operation of the wallmount ventilator by a building management system is available by connecting to the terminals described above. For full control of the wallmount ventilator by the management system, external switches (if equipped) should be set to 'Off'. External switches set to 'On' will override the building management control. Each operation is activated by switching terminal R to the corresponding terminal.

### Airflow Balancing

Once installed, the wallmount ventilator must operate with balanced ventilation. Balanced ventilation is achieved by obtaining equal rates of supply and exhaust airflow. Airflow may be adjusted by balancing dampers (supplied by installer) within the supply and exhaust ductwork.

Systems that are not operating with balanced airflow will not have effective energy recovery. Performance of the heat recovery module will be reduced and freezing may occur with cold outside air temperatures, resulting in blockage of the heat recovery module.

## System Operation

*Building Management Systems will vary*

### Sequence of Operation

#### Electric Models

The operating sequence is summarized by the following:

Signal from:

Internal Stat - stage 1 heating

Signal to W1 - stage 2 heating

- fans to low speed

- send signal to baseboard contactors  
(optional in field only)

Signal to W2 - supply fan on

- exhaust fan off

- stage 1 heating

- close ventilation damper

Signal to Y1 - supply fan to 'High' and exhaust fan  
'Off' (free cooling)

Signal to Y2 - Air conditioning (optional)

- open recirc damper (HRV450w ONLY)

- connection for condensing unit

Signal to S1 - engage occupied mode

No signal to S1 - engage unoccupied mode (fans off)  
and close vent damper. On a call for  
heat/cool the supply fan runs only in  
recirculation mode (with frost control  
option installed).

With the thermostat and subbase, connect terminal G on the subbase to the terminal 'G' in the control box. This will enable the ventilation to run on occupied cycles when the 'Ventilation Rate' switch is on either 'High' or 'Low' and the T7350 'Fan' operation shows 'On' in the lower right area of the display screen. When the 'Fan' operation shows 'Auto' only, a call for heat or cool will engage fan operation. Press the 'Fan' button on the T7350 to alternate between 'On' and 'Auto'. See Appendix F for the wiring details.

#### Hydronic Models

The operating sequence is summarized by the following:

Signal from:

Signal to W1 - fans to low speed (duct stat to control  
zone valve)

Signal to W2 - supply fan 'High'

- exhaust fan 'Off'

- close ventilation damper

Signal to Y1 - free cooling mode

- supply fan on 'High' and exhaust fan 'Off'

Signal to Y2 - air conditioning

- connection for condensing unit

Signal to S1 - engage occupied mode

No signal to S1 - engage unoccupied mode (fans off) and  
close vent damper (for units equipped  
with frost control). On a call for heat/cool  
the supply fan operates only.

## Ventilation

Fan speed can be selected by setting the external 'Ventilation Rate' switch to 'Low', 'Off', or 'High'. The 'Fan' operation on the T7350 must show 'On', in the lower right area of the display screen, for continuous ventilation. If you do not require ventilation, press the 'Fan' key to set the unit to 'Auto'. If ventilation is required, press the 'Fan' key to set the unit to 'On'. When the unit goes into the unoccupied mode, the ventilation will shut down even if the display shows the 'On' operation.

## Heating

#### Electric

An internal thermostat acts as a supply air temperature monitor and engages heating as necessary to preheat supply air before delivering it to the space being ventilated. This thermostat comes with all electric heat models. This thermostat is not available with hydronic heating.

The thermostat contacts R and B make a closure on temperature fall which engages the heating contactor. The thermostat is factory set at 15°C/59°F (actual 13°C/55°F with differential set at 2). For proper environment conditions, the temperature of the supply air diffused should be no lower than 55°F. This thermostat can be deactivated by turning the 'First Stage Heating' switch to the 'Off' position. Further instructions for setting the thermostat are given in Appendix G.

If no heating is required at all, then the first stage heating switch should be in the 'Off' position and the T7350 should display either 'Off' or 'Cool'. During cooling season, the 'First Stage Heating' switch should be in the 'Off' position.

#### Hydronic

Units equipped with hot water heating coils will come **without** controls for controlling flow, etc. Hot water piping connections are shown in Appendix A-2 and B-2. Control valve is to be hooked up to a remote duct stat supplied by others (optional connection to W1 on the subbase). All wiring is low voltage. This operation is single stage and on a second stage call for heat the supply fan will go to high speed, the exhaust fan will shut off, and the unit will go into recirc mode. See Appendix A-2 and B-2 for more details.

## High Temperature Limit Control

*(Electric models only)*

Temperature limit thermostats in the heating circuit will break contact to the heating elements when the temperature rise across the heating elements becomes excessive. This may be due to blocked filters, blocked energy recovery module, blocked ducting, fan failure or fan relay failure. See the System Service Section for proper equipment maintenance.

## First Stage Cooling

First stage cooling puts the supply fan to high speed and the exhaust fan shuts off.

## Second Stage Cooling - Air Conditioning

Second stage cooling is an option and will call for Dx cooling from a remote condensing unit. Both fans will run on high speed.

Air conditioning is provided as an option. A field connection from Y2 on the terminal block (inside control box) must be run to the contactor in the remote condensing unit. This line will be 24 VAC hot. If a return line is also required for the contactor, it can be taken from terminal C. See wiring diagram in control box for further details. Suction and liquid line connections are made at the coil (equipped with solder connects).

Holes in the top supply plenum are to be field drilled to accommodate the refrigerant lines. On a call for cooling, both fans will go to high speed and the recirc damper on the right side of the unit will open to allow for increased airflow over the coil.

### WARNING

To prevent poor performance for air conditioning allow 4" to 6" [102 to 152mm] from the right side to any wall or partition.

## Air Conditioning Coil Installation

Place the provided insulation on top of the unit over the matching supply opening. Place the coil and drain pan assembly over the insulation and supply air opening. Place clips in opposing corners of coil drain pan and fasten down to the top of unit with screws. Leave enough clearance around the back and side edges of the unit to allow installation of the top supply discharge plenum or ducting as required.

See Appendix A-2 and B-2 for installing the air conditioning coil on top of the wallmount ventilator.

## Recirculation Control

In the HRV450w ventilation mode, the ventilation damper is open and the supply air is 100% outdoor air. In the HRV1000w ventilation mode, the ventilation damper is open and the supply air is a mixture with a percentage of return air (See Appendix C-2 or C-3).

In recirculation mode, the ventilation damper is closed, 100% of the supply air is recirculated air from the return plenum. Units equipped with recirculation control are built with a damper mechanism controlling airflow through the intake duct. Ventilation mode is activated by a signal to terminal S1. Recirculation mode is activated when there is a signal from W2 or when there is no signal to S1.

## Frost Control

Units with frost control are equipped with recirculation control. Frost control consists of a timer/controller which is activated by a thermostat which monitors the outside air temperature passing through the air intake.

When the HRV450w and HRV1000w are in ventilation mode at temperatures below 23°F [-5°C], the frost control timer/controller activates recirculation control periodically

to keep the flat plate heat exchanger free from frost.

## Freeze Control Temperature Disc

A bi-metallic disc (field installed) is provided with hydronic units to prevent the coils from freezing up. This disc is located near the supply fan and is to be connected to the zone valve that controls the flow to the coil. When the temperature in the cabinet goes below freezing, the disc closes its contacts to engage the flow through the coil to prevent the coil from freezing. See the wiring diagram on unit control box cover for more details.

### WARNING

Disconnect power before maintaining the unit.

## System Service

### Monthly Maintenance

#### Air Filters

##### *HRV450w*

The washable black foam filters should be cleaned monthly or as required by operating conditions. The optional medium efficiency filters are disposable and should be replaced monthly or as required by operating conditions. To remove the filters, simply remove the top



**HRV450w Exhaust Filter**

access door and slide the filter out of the guide (See below). When installing a new filter, the airflow arrow should point in the direction of the heat exchanger.

##### *HRV1000w*

The standard medium efficiency filters are disposable and should be replaced monthly or as required by operating conditions. When installing a new filter, the airflow arrow should point in the direction of the heat exchanger.

To remove the *HRV1000w* filters, simply remove the bottom access door and slide the filter out of the guide.



**HRV1000w Exhaust Filter**



**HRV1000w Supply Filter**

## Annual Maintenance

### Drain Pans and Interior of Unit

The inside of the unit, including drain pans (if equipped), should be wiped clean annually with a soft cloth and mild cleaning solution. Check the drain fittings (if equipped) to ensure they are draining freely.

### Plate Heat Exchanger

Clean the heat recovery module by removing it from the unit and washing out the spaces between the plates using a mild detergent. If a high pressure hose is used, avoid causing damage to the exchanger by making sure that the nozzle does not get too close to it.

### Heaters/Air Conditioning Coils

Check the duct heaters, hot water coils and air conditioning coils for obstruction or build-up of dust. Check the manual reset button on your duct heaters (if unit has electric heat). If the red buttons are released out, depress the red button to reset the switch. If this problem persists, call your local technician.

### Dampers

Check inside dampers for obstruction and cleanliness.

## Fans

Blower wheels and fan housings should be checked for dust build-up. If excessive dust build-up exists, it will be necessary to remove the blower assembly to clean the dust out through the fan mouth.

To remove the supply blower, first remove the two screws holding the blower in place, disconnect the electrical plug and slide the blower out of the unit.

To remove the exhaust blower, the control box has to be removed. Disconnect the electrical plugs from the control box and remove the four screws holding it in place to expose the exhaust blower. Remove the two wing screws and slide the exhaust blower out.



**Removing the Supply Blower**

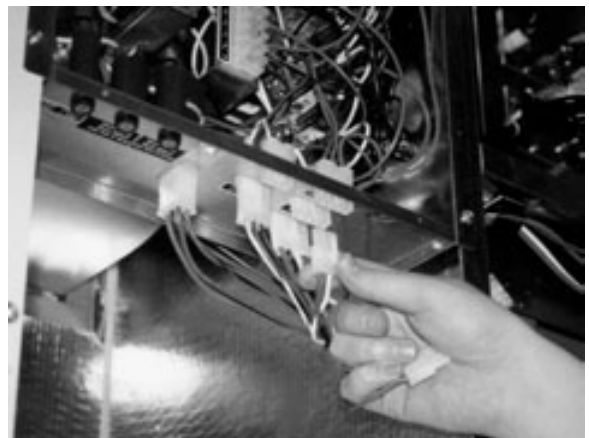

**Disconnect Electrical Plugs**



**Removing the Supply Blower**

# Appendix A

## A-1: HRV450w Overall Dimensions

TOP VIEW WITH  
DUCTED SUPPLY PLENUM

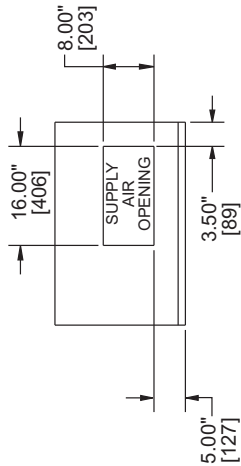

NOTES:

- 1) Dimensions in [ ] are millimeters.
- 2) Direction of airflow
- 3) Factory supplied outdoor air louvers require wall penetrations as shown for air duct opening sizes.
- 4) Maintenance: Allow minimum 24" [610] clearance for front access.

24.00" x 6.00" [610 x 153]  
DOUBLE DEFLECTION GRILL

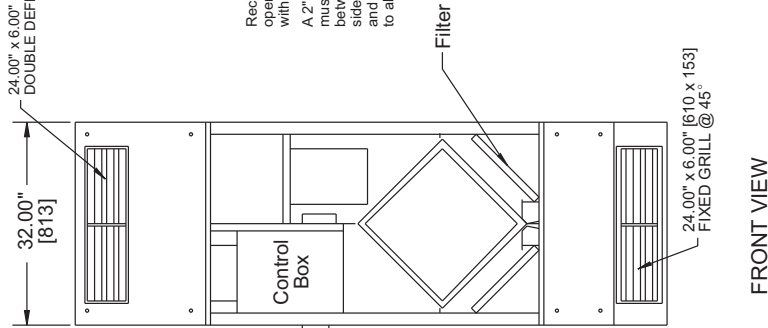

FRONT VIEW

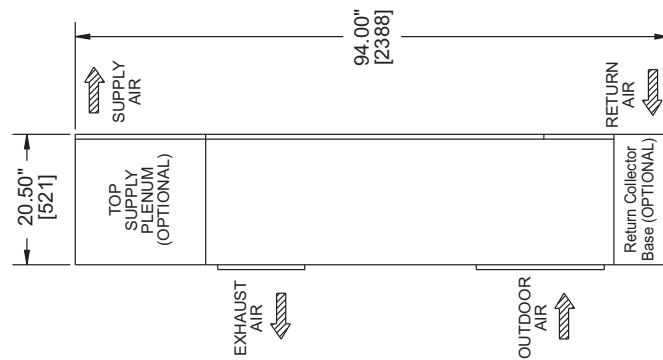

LEFT VIEW

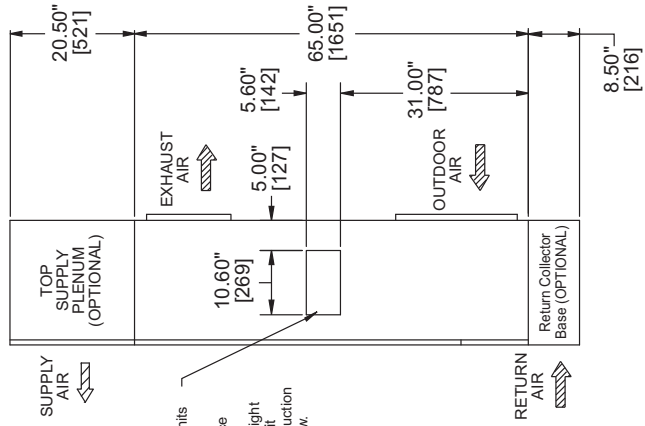

RIGHT VIEW

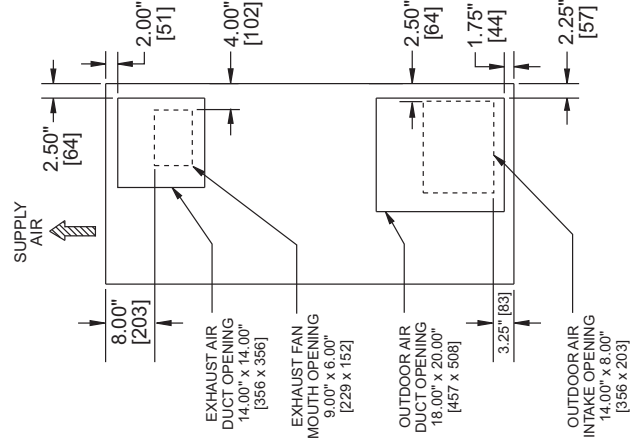

BACK VIEW

# Appendix A

## A-2: HRV450w Coil Dimension Drawings

### DX COOLING

CONNECTION TABLE		CONNECTION SIZES	
(A)	Field power supply outlet	1	1/8"
(B)	Supply	3/8"	(SWEAT)
(C)	Suction	3/4"	(SWEAT)

TOP VIEW WITHOUT SUPPLY PLENUM

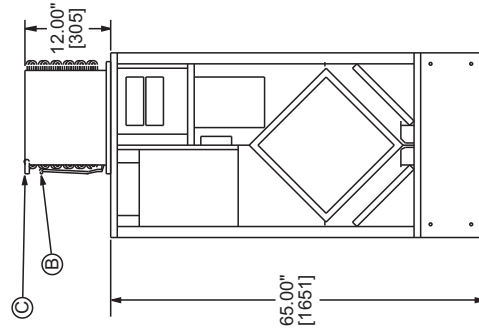
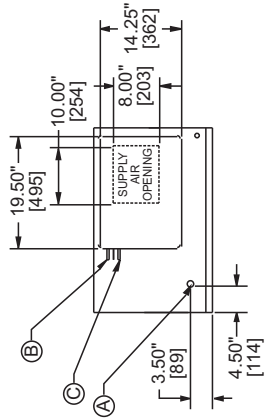

FRONT VIEW

**NOTE:**  
Drain for condensate for cooling coil will have to be installed out the bottom of the unit.

### ELECTRIC HEAT

CONNECTION TABLE		CONNECTION SIZES	
(A)	Field power supply outlet	1	1/8"

TOP VIEW WITHOUT SUPPLY PLENUM

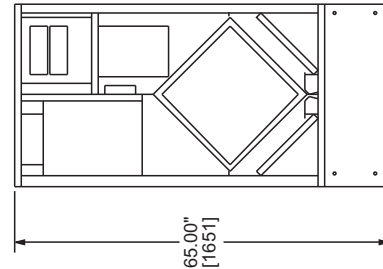
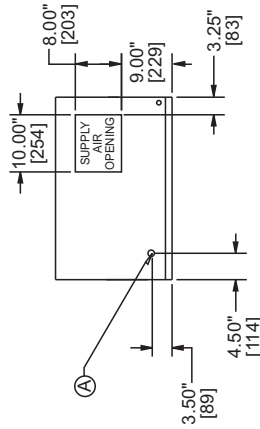

FRONT VIEW

### 25/50 MBTU HYDRONIC

CONNECTION TABLE		CONNECTION SIZES	
(A)	Field power supply outlet	1	1/8"
(B)	Coil connection	7/8"	(SWEAT)
(C)	Coil connection	7/8"	(SWEAT)

TOP VIEW WITHOUT SUPPLY PLENUM

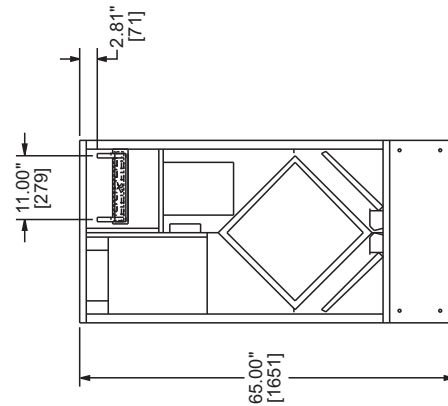
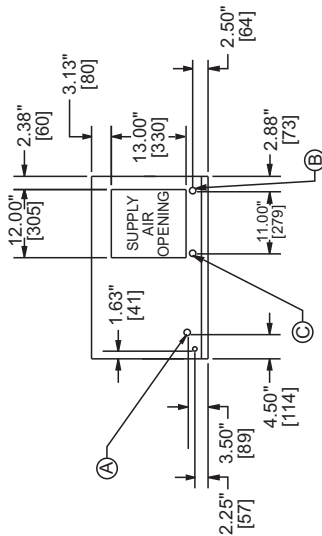

FRONT VIEW

# Appendix B

## B-1: HRV1000w Overall Dimensions

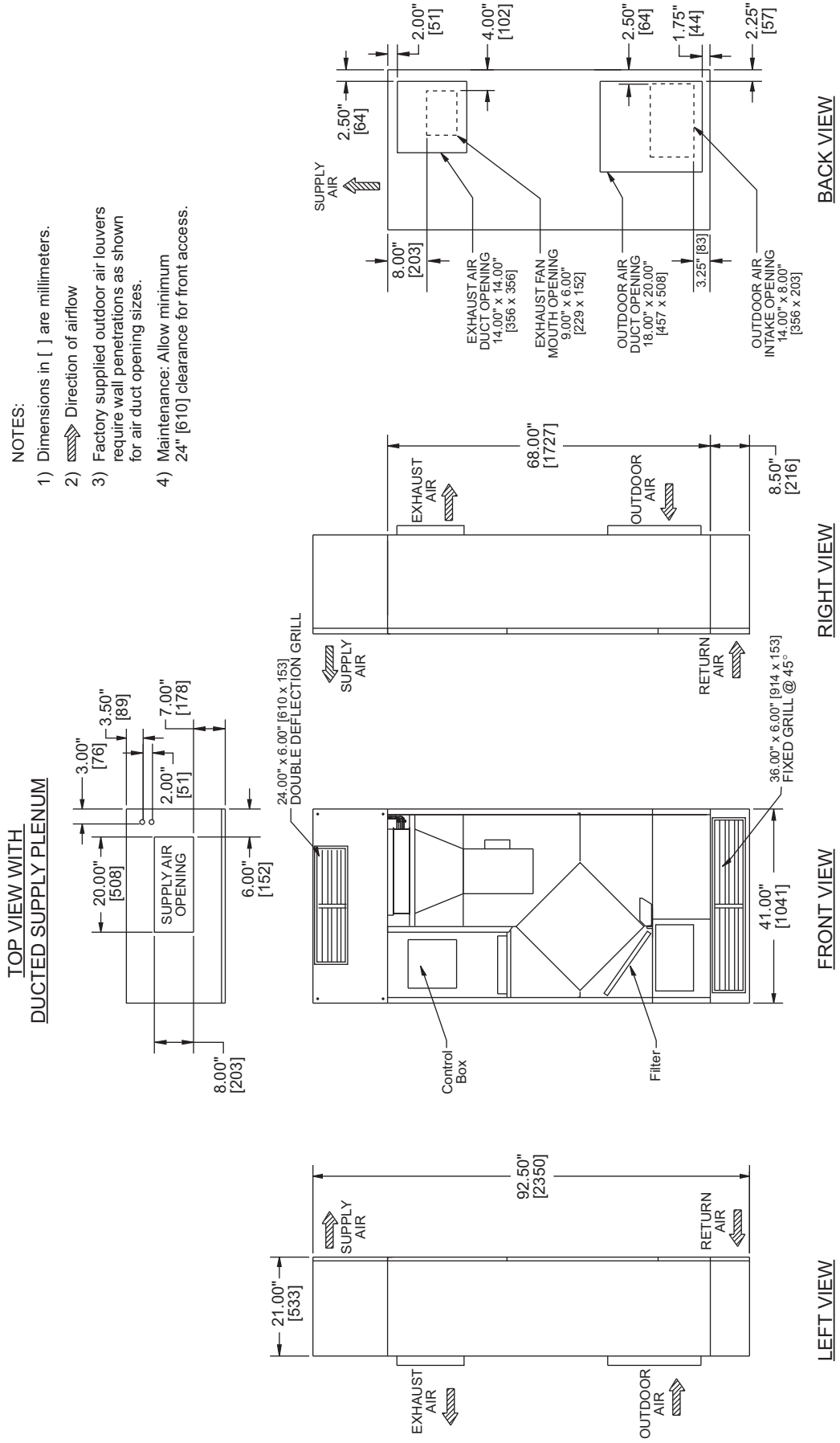

## Appendix B

### B-2: HRV1000w Coil Dimension Drawings

#### DX COOLING

CONNECTION TABLE		CONNECTION SIZES
(A)	Field power supply outlet	1 1/4"
(B)	Supply	3/8" (SWEAT)
(C)	Suction	3/4" (SWEAT)

TOP VIEW  
WITHOUT SUPPLY PLENUM

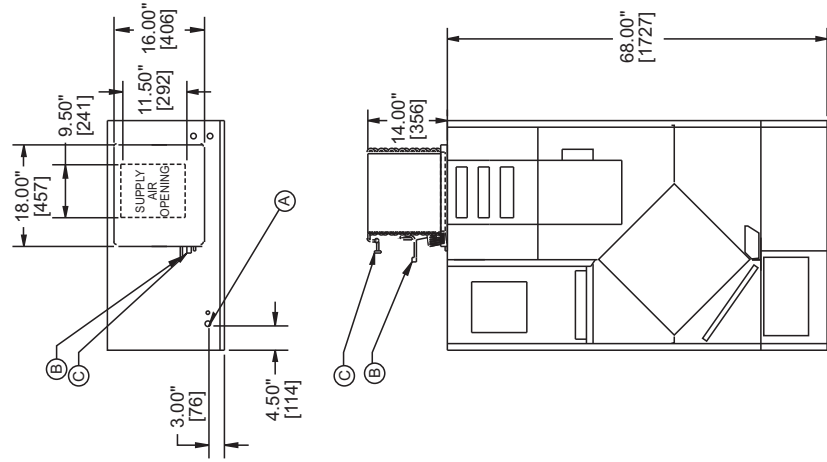

FRONT VIEW

**NOTE:** Drain for condensate for cooling coil will have to be installed out the bottom of the unit.

#### ELECTRIC HEAT

CONNECTION TABLE		CONNECTION SIZES
(A)	Field power supply outlet	1 1/4"

TOP VIEW  
WITHOUT SUPPLY PLENUM

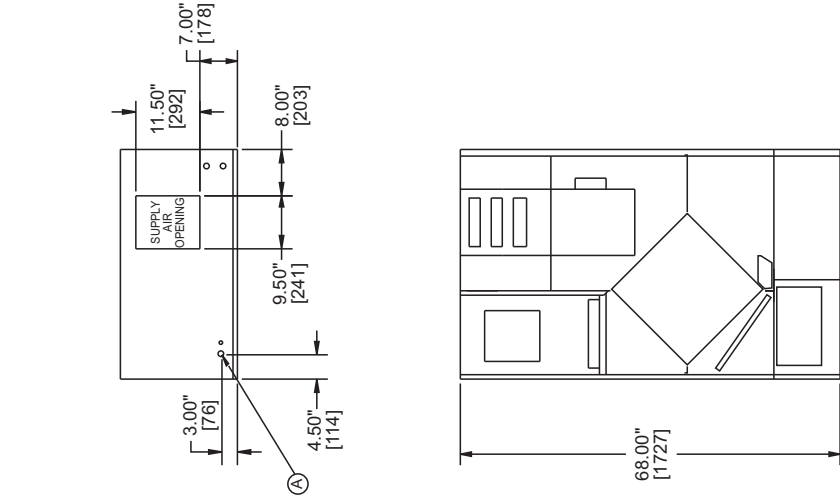

FRONT VIEW

#### HYDRONIC HEAT

CONNECTION TABLE		CONNECTION SIZES
(A)	Field power supply outlet	1 1/4"
(B)	Coil connection	1/2" (SWEAT)
(C)	Coil connection	1/2" (SWEAT)

TOP VIEW  
WITHOUT SUPPLY PLENUM

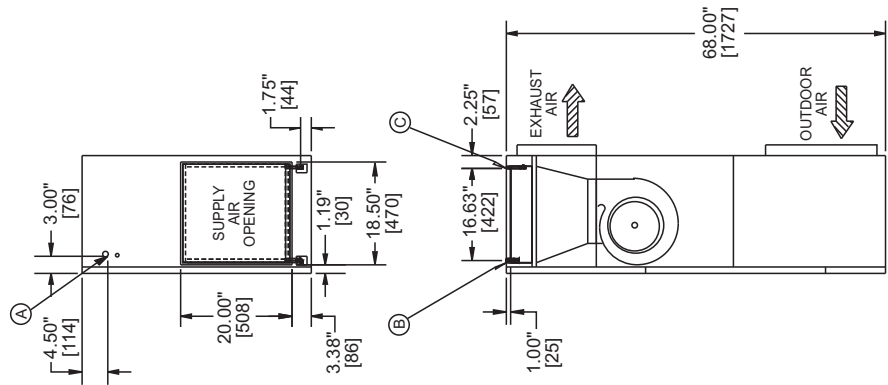

RIGHT VIEW

## Appendix C

### C-1: HRV450w Ventilation Graph

ESP (in. wg.)	Poly Core Low Speed	Poly Core High Speed	AL Core Low Speed	AL Core High Speed	Recirc. Open for Dx Cooling
0.00	460	685	460	710	800
0.10	435	630	445	665	750
0.15	415	600	435	640	725
0.20	400	580	425	605	705
0.25	380	550	410	585	675
0.30	365	510	390	555	645
0.35	340	480	375	540	605
0.40	305	435	355	495	570
0.45	280	410	335	460	530
0.50	250	375	295	430	495
0.55	220	335	265	395	460
0.60	190	n/a	235	340	415

**NOTE:** External static pressure is calculated by totalling the individual air pressure drops for the following options: electric heat, hot water heat, evaporator cooling coil, top supply plenum and louvers.

### C-2: HRV1000w Reduced Low Speed Airflow Information

Supply Fan	ESP (IWG)	Position of Recirc Panel										
		Fully Closed	1			2		3		4		Fully Open
		TA (CFM)	TA (CFM)	OA (CFM)	TA (CFM)	OA (CFM)	TA (CFM)	OA (CFM)	TA (CFM)	OA (CFM)	TA (CFM)	OA (CFM)
Speed 1	0.00	920	1150	890	1270	860	1360	855	1400	685	1430	650
	0.10	885	1095	870	1215	830	1300	815	1345	665	1360	635
	0.20	830	1050	835	1160	810	1245	795	1270	645	1300	625
	0.30	790	985	805	1120	780	1190	755	1205	625	1245	610
	0.40	725	935	770	1060	750	1135	735	1150	615	1180	590
	0.50	685	885	740	995	710	1075	710	1080	595	1095	575
	0.60	610	810	690	945	675	1015	665	1000	575	1020	550
	0.70	545	745	640	855	635	915	635	900	545	920	520
	0.80	455	670	600	775	600	820	590	790	505	810	485
	0.90	-	545	540	645	540	715	540	660	465	675	450
1.00	-	-	-	-	-	555	475	490	415	490	390	
Speed 2	0.00	870	1020	810	-	-	-	-	-	-	-	-
	0.10	835	970	785	1075	745	1090	705	1095	570	1110	565
	0.20	775	935	765	1025	730	1060	690	1065	565	1065	555
	0.30	735	885	735	980	700	1030	675	1020	550	1035	550
	0.40	685	845	710	930	670	980	655	970	540	970	535
	0.50	625	805	685	895	650	930	630	920	530	940	530
	0.60	575	735	640	845	625	880	610	860	510	900	515
	0.70	505	670	600	765	595	815	580	785	485	830	490
	0.80	405	585	555	680	555	725	545	670	445	730	450
	0.90	-	-	-	550	490	605	490	545	405	600	420
Speed 3	0.00	-	-	-	-	-	-	-	-	-	-	-
	0.10	765	815	680	-	-	-	-	-	-	-	-
	0.20	715	795	670	845	615	865	595	860	495	865	485
	0.30	660	765	650	835	610	845	585	815	490	845	475
	0.40	610	735	630	785	600	805	570	795	485	810	470
	0.50	575	705	615	765	585	785	565	745	465	780	465
	0.60	520	650	595	710	550	735	535	695	450	730	450
	0.70	420	585	555	655	540	670	510	625	430	660	435
	0.80	365	505	510	565	495	580	475	545	415	560	405
	0.90	-	-	-	-	-	460	420	385	355	455	375
Speed 4	0.00	-	-	-	-	-	-	-	-	-	-	-
	0.10	650	-	-	-	-	-	-	-	-	-	-
	0.20	610	-	-	-	-	-	-	-	-	-	-
	0.30	575	635	570	665	530	670	510	660	435	650	420
	0.40	540	610	565	655	520	655	505	635	430	640	415
	0.50	485	585	555	630	515	620	490	610	420	615	415
	0.60	430	545	530	580	505	595	475	585	415	575	405
	0.70	365	490	490	525	470	540	455	520	395	505	390
	0.80	-	-	-	405	415	460	420	420	365	405	365

Additional internal static pressure due to accessories must be known to determine ESP.

This data includes factory selected louver and electric heat coils.

O.A. balancing damper may be required to achieve desired ventilation air volume.

Exhaust fan is set to low speed for highlighted cells.

## Appendix C

### C-3: HRV1000w High Speed and Regular Low Speed Airflow Information

Supply Fan	ESP (IWG)	Position of Recirc Panel										
		Fully Closed	1		2		3		4		Fully Open	
		TA (CFM)	TA (CFM)	OA (CFM)	TA (CFM)	OA (CFM)	TA (CFM)	OA (CFM)	TA (CFM)	OA (CFM)	TA (CFM)	OA (CFM)
Speed 1	0.00	1000	1230	875	1355	855	1470	825	1560	805	1605	790
	0.10	950	1180	835	1305	835	1415	795	1510	785	1540	770
	0.20	895	1105	815	1240	805	1355	775	1445	760	1465	740
	0.30	840	1045	795	1190	770	1295	750	1360	725	1395	710
	0.40	780	980	755	1135	740	1215	710	1290	700	1315	680
	0.50	715	915	710	1060	710	1145	690	1225	680	1235	655
	0.60	645	840	665	995	675	1075	655	1140	640	1170	635
	0.70	565	745	620	910	635	980	620	1055	610	1070	600
	0.80	445	660	565	805	590	875	575	940	580	975	570
	0.90	-	-	-	680	535	765	540	780	515	835	520
1.00	-	-	-	-	-	-	-	-	-	-	-	
Speed 2	0.00	1000	1190	855	1305	820	1390	790	1455	760	1500	745
	0.10	940	1135	815	1255	795	1330	770	1410	740	1445	720
	0.20	880	1090	805	1190	770	1270	740	1350	420	1375	705
	0.30	815	1030	770	1135	745	1215	715	1290	700	1300	680
	0.40	755	965	740	1075	710	1145	685	1210	660	1235	655
	0.50	680	895	690	1010	680	1090	665	1130	640	1170	635
	0.60	620	825	645	945	645	1010	640	1070	610	1085	610
	0.70	525	735	600	850	600	925	595	960	575	990	575
	0.80	-	630	545	765	575	835	565	865	550	885	550
	0.90	-	-	-	630	510	700	510	710	490	740	495
Speed 3	0.00	960	1120	820	1200	775	1280	745	1300	695	1325	675
	0.10	910	1075	795	1145	745	1230	715	1250	670	1290	660
	0.20	845	1030	770	1105	720	1175	700	1210	655	1235	650
	0.30	785	965	730	1060	705	1130	670	1155	640	1185	640
	0.40	725	915	700	995	670	1075	650	1100	620	1130	625
	0.50	670	840	670	945	635	995	615	1040	600	1055	595
	0.60	595	775	625	875	605	925	595	960	575	990	575
	0.70	495	690	575	785	580	850	555	865	550	895	550
	0.80	390	580	505	680	540	745	520	780	515	800	515
	0.90	-	-	-	-	-	605	465	640	470	740	450
Speed 4	0.00	910	1025	745	1075	690	1090	655	1070	620	-	-
	0.10	865	985	730	1010	670	1075	640	1055	610	1070	595
	0.20	805	935	700	980	655	1040	625	1005	600	1055	590
	0.30	745	880	675	945	640	1025	615	960	580	1025	580
	0.40	680	825	645	850	595	960	600	905	555	975	565
	0.50	620	765	610	805	585	910	575	855	540	925	550
	0.60	550	705	590	775	575	840	550	780	515	865	540
	0.70	440	620	490	700	540	765	530	675	475	790	515
	0.80	-	-	-	605	410	655	475	-	-	685	470

Additional internal static pressure due to accessories must be known to determine ESP.

This data includes factory selected louver and electric heat coils.

O.A. balancing damper may be required to achieve desired ventilation air volume.

Exhaust fan is set to low speed for highlighted cells.

## Appendix D

### Electrical Data

#### 208 VAC HRV450w Electric Heat

Amount of Heat	MCA	MOP	Btu/hr	A/C Option			
				1 1/2 Ton		2 Ton	
				kW	Btu/hr	kW	Btu/hr
2.5 kW	20.6	25	8,533	5.3	18,000	7.0	24,000
5.0 kW	35.6	40	17,065	5.3	18,000	7.0	24,000
7.5 kW	50.8	60	25,598	5.3	18,000	7.0	24,000
10.0 kW	65.8	70	34,130	5.3	18,000	7.0	24,000

#### 230 VAC HRV450w Electric Heat

Amount of Heat	MCA	MOP	Btu/hr	A/C Option			
				1 1/2 Ton		2 Ton	
				kW	Btu/hr	kW	Btu/hr
2.5 kW	19.3	20	8,533	5.3	18,000	7.0	24,000
5.0 kW	32.8	35	17,065	5.3	18,000	7.0	24,000
7.5 kW	46.4	50	25,598	5.3	18,000	7.0	24,000
10.0 kW	60.0	60	34,130	5.3	18,000	7.0	24,000

#### 120 VAC HRV450w Hydronic Heat

Amount of Heat	MCA	MOP	kW	Btu/hr	A/C Option			
					1 1/2 Ton		2 Ton	
					kW	Btu/hr	kW	Btu/hr
No heat	5.6	9	0	0	5.3	18,000	7.0	24,000
25 MBH H <sub>2</sub> O coil	5.6	9	6.7	23,000	5.3	18,000	7.0	24,000
50 MBH H <sub>2</sub> O coil	5.6	9	10.8	37,000	5.3	18,000	7.0	24,000

#### 208 VAC HRV1000w Electric Heat

Amount of Heat	MCA	MOP	Btu/hr	A/C Option - 3 ton	
				kW	Btu/hr
2.5 kW	22.8	25	8,533	10.5	36,000
5.0 kW	37.8	40	17,065	10.5	36,000
7.5 kW	52.9	60	25,598	10.5	36,000
10.0 kW	67.9	70	34,130	10.5	36,000
12.5 kW	82.9	90	42,663	10.5	36,000
15.0 kW	97.9	100	51,195	10.5	36,000

#### 230 VAC HRV1000w Electric Heat

Amount of Heat	MCA	MOP	Btu/hr	A/C Option - 3 ton	
				kW	Btu/hr
2.5 kW	21.4	25	8,533	10.5	36,000
5.0 kW	34.9	35	17,065	10.5	36,000
7.5 kW	48.5	50	25,598	10.5	36,000
10.0 kW	62.1	70	34,130	10.5	36,000
12.5 kW	75.6	80	42,663	10.5	36,000
15.0 kW	89.3	90	51,195	10.5	36,000

#### 120 VAC HRV1000w Hydronic Heat

Amount of Heat	MCA	MOP	kW	Btu/hr	A/C Option - 3 ton	
					kW	Btu/hr
No heat	12.1	15	0	0	10.5	36,000
50 MBH H <sub>2</sub> O coil	12.1	15	14.6	50,000	10.5	36,000
70 MBH H <sub>2</sub> O coil	12.1	15	20.5	70,000	10.5	36,000

## Appendix E

### Low Voltage and High Voltage Wiring

#### Connections to Terminal Block in Control Box

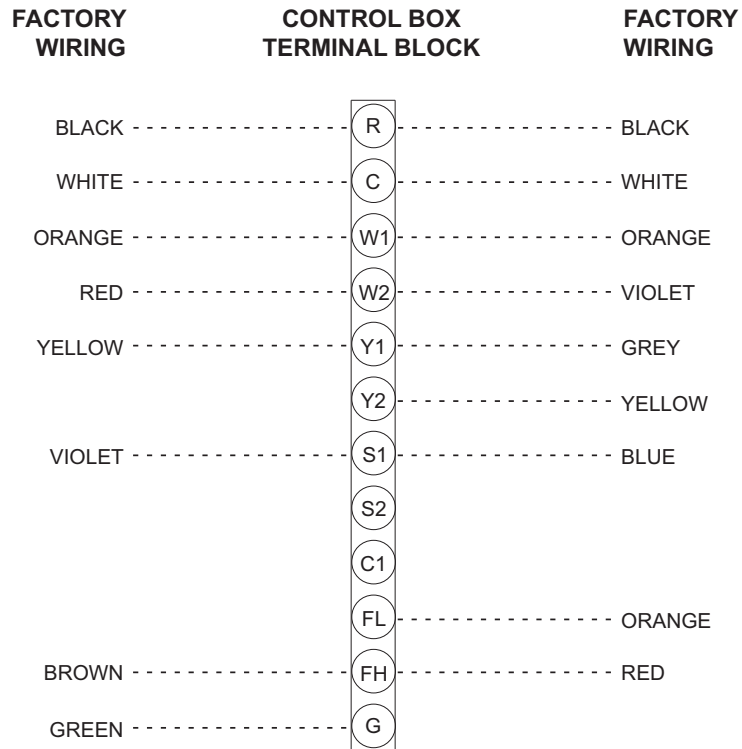

#### Single Phase Power Supply Wiring

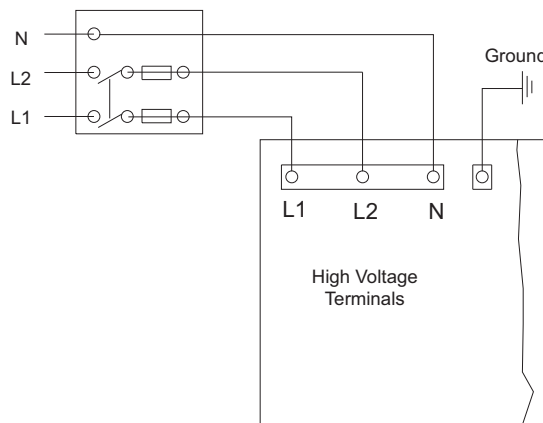

**NOTES:**

- 1) Fused disconnect switch supplied by installer.
- 2) 208-230 VAC/120/1/60 requires a neutral wire to be run with L1 and L2.
- 3) For 120/1/60 volt units, L2 is not required.

## Appendix F

### Thermostat and Wiring Connections

#### Thermostat Subbase Set Up

Factory supplied thermostats and subbases are configured and ready for installation. Use this information to configure thermostats that are field supplied.

Install jumper wires across the following terminals, refer to figure below - Subbase:

#### Jumper Connections - Subbase

- 1 - Rh to Rc (Factory installed)

Connections R,C,W, etc. to ventilation unit are as shown:

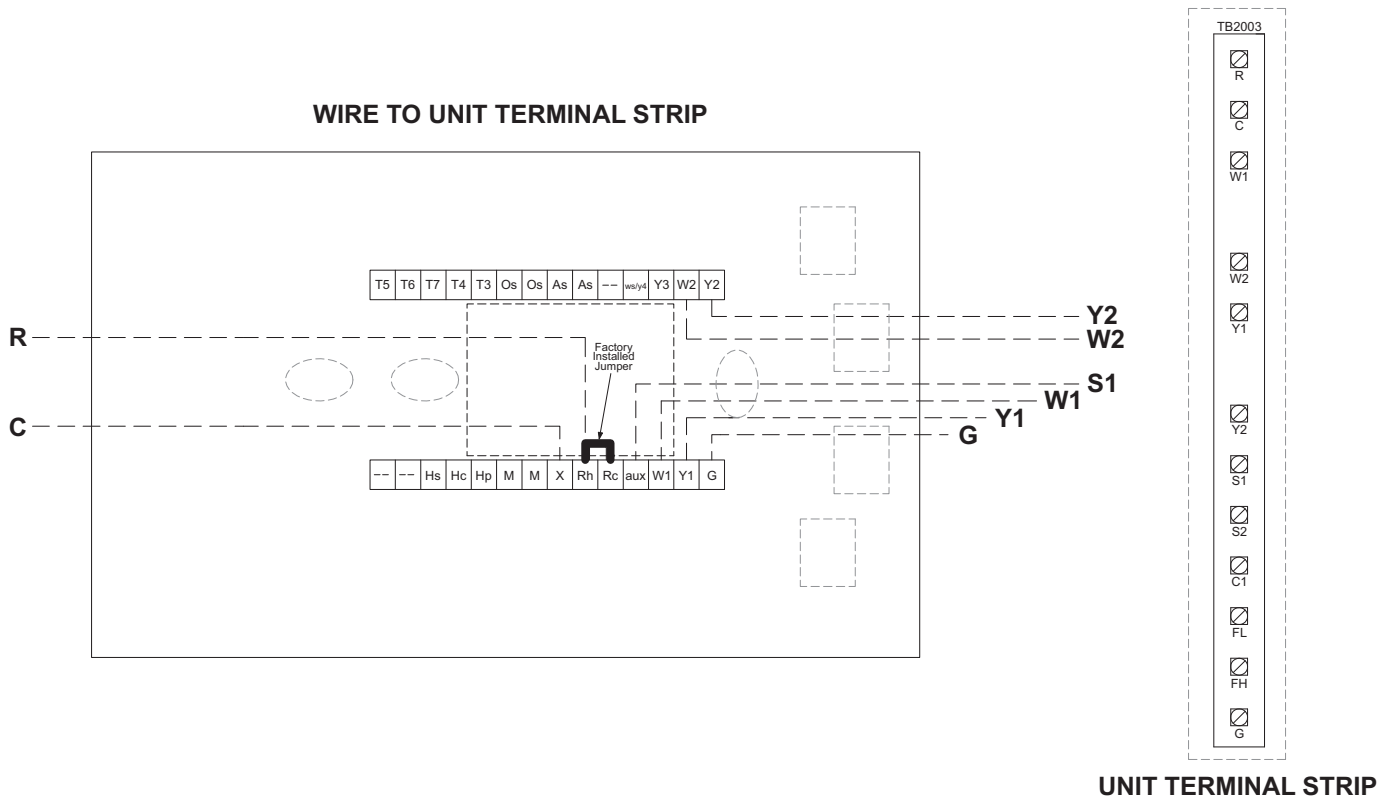

#### Thermostat Set Up

See the manufacturer's instruction manual for detailed instructions on how to program the following thermostat functions that must be set:

- 1) Day of the Week
- 2) Time
- 3) Daily Schedules
- 4) System (Heat, Cool, Automatic)
- 5) Fan (On, Auto)

## Appendix G

### Internal Thermostat

#### T675A

As the temperature of the controlled medium falls below the setpoint less differential, the T675A switch makes terminals R to B and energizes a normally closed solenoid valve to provide heat. In cooling applications, the T675A makes terminals R to W as the temperature rises above the set point, energizing cooling equipment. Figure 1 shows the operation of the T675A. Figure 2 shows the location of the adjustment dial on models with an adjustable differential.

#### Freeze-up Protection

When using the T675A (auto-recycling) for freeze-up protection, the recommended setpoint is 38°F [3.3°C] plus the switch differential.

**EXAMPLE:** Setpoint of 38°F [3.3°C] plus 1°F [0.6°C] (fixed differential model) equals an actual setpoint of 39°F [3.9°C].

**EXAMPLE:** Setpoint of 38°F [3.3°C] plus 3°F [1.7°C] (adjustable differential model) equals an actual setpoint of 41°F [5°C].

This provides an adequate safety factor for freeze-up protection.

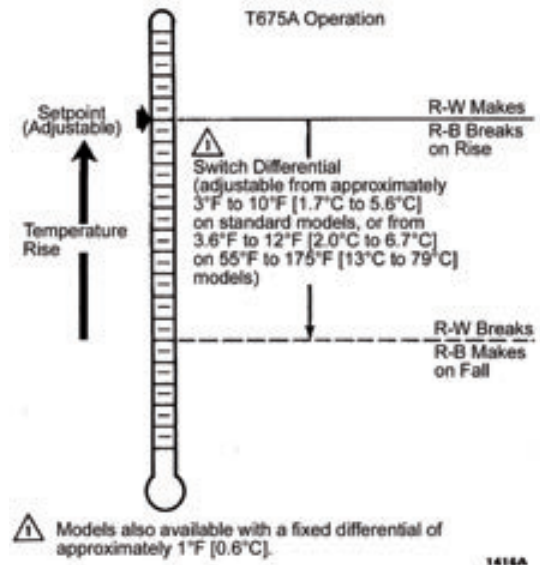

Figure 1: Operation of the T675A

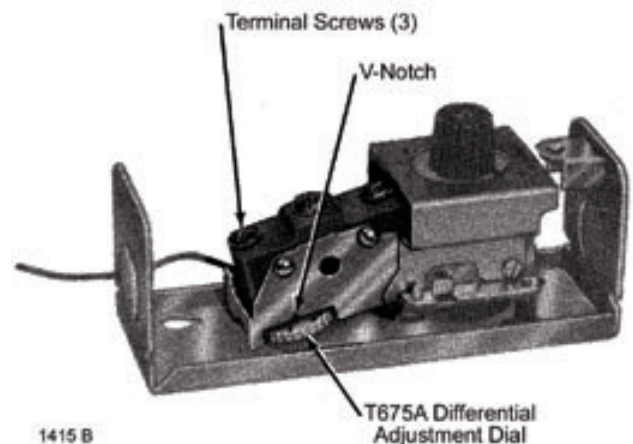

Figure 2: Location of the adjustment dial on T675A models with an adjustable differential

Venmar CES products are licensed to use  
the following label of approval:



**Venmar CES Inc.**  
Saskatoon, SK Canada

[www.venmarces.com](http://www.venmarces.com)